

BACK VIEW

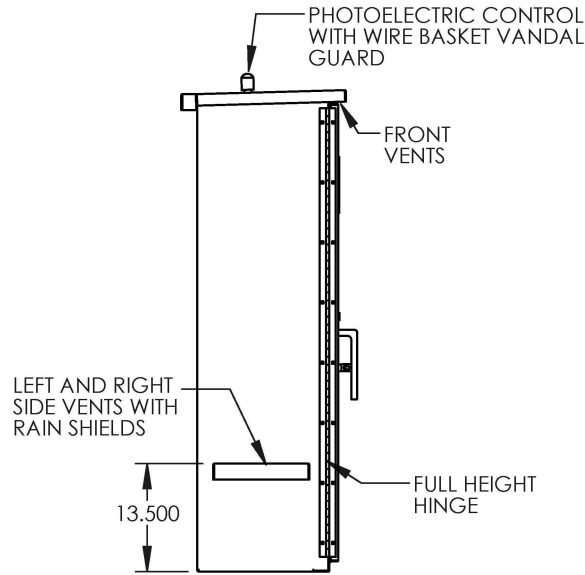

LEFT SIDE VIEW

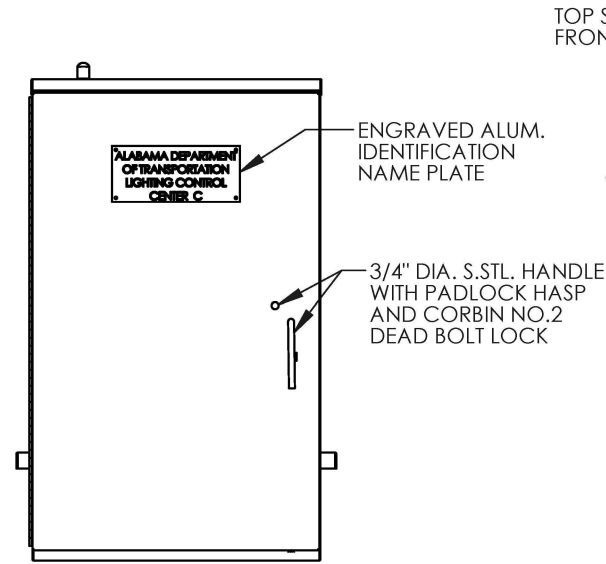

FRONT VIEW

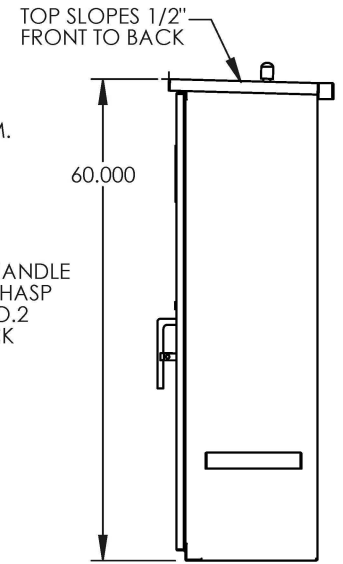

RIGHT SIDE VIEW

1. Proudly made in America at our ISO 9001:2008 registered facility.
2. Enclosure is constructed to Alabama Department of Transportation Lighting Load Center Drawing RLD002 dated 04/29/2011.
3. Handle, 3/4" dia. stainless steel pad-lockable hasp.
4. Lock, deadbolt, CORBIN style, keyed #2, main door with two keys each.
5. Latching, three point door with nylon rollers for top and bottom strikers.
6. Door stop rod, three position (90,120, and 180 degrees).
7. Neoprene door gasket.
8. Top slopes 1/2 inch front to back.
9. Vent holes in front face rail, covered with aluminum screen, with top lid overhang to provide drip shield.
10. Vent holes in rear body, covered with aluminum screen, provided with drip shield.
11. Perforated vents on right and left side with vent hood per drawing.
12. Stainless steel hardware.
13. Continuous stainless steel door hinge.
14. Door switch bracket.
15. Photoelectric control with wire bracket vandal guard.
16. Engraved aluminum identification nameplate attached to door. One inch high lettering "ALABAMA DEPARTMENT OF TRANSPORTATION LIGHTING CONTROL CENTER \*". (\* - indicates letter designation of cabinet, A,B,C, or D). Engraved lettering to be delineated in black enamel.

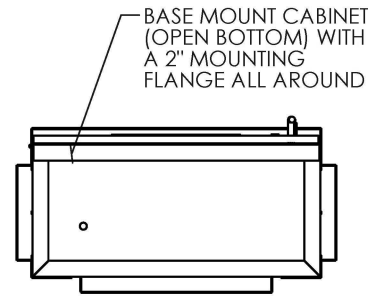

BOTTOM VIEW



**Southern Manufacturing**  
 150 Hope Street  
 Longwood, FL 32750  
 ph: 407-894-8851  
 fx: 407-831-1508

MATERIAL: 5052H-32 ALUMINUM .125"

FINISH:

	NAME	DATE
DRAWN By:	SAS	06/27/2012
CHECKED:		
MFG APPR:		
Cust APPR:		

**SOUTHERN MFG. CO.**

P/N: CA-60X36X16.5-MAIN-ASSY-3

1/8" ALUMINUM 3R CABINET  
 60X36X16.5 BASE MOUNTED

Rev: 0

Scale: 1:24 Sheet 1 of 21

SIZE **A**

PROPRIETARY AND CONFIDENTIAL

The information contained in this drawing is the sole property of Southern Manufacturing. Any reproduction in part or as a whole without the written permission of Southern Manufacturing is prohibited.