

CLEAN PROFILE

Illuminated Street Name Signs Regulatory & Warning Signs

The CLEAN PROFILE edge lit signs are the latest addition in Southern's extensive line of internally illuminated street name signs. Southern was an early adaptor of LEDs into illuminated street name signs and with an installed base of over 10,000 signs nationwide. Since its introduction in 2010, the Clean Profile sign has become our most popular style. The versatility makes it ideal for regulatory signs as well as street name signs.

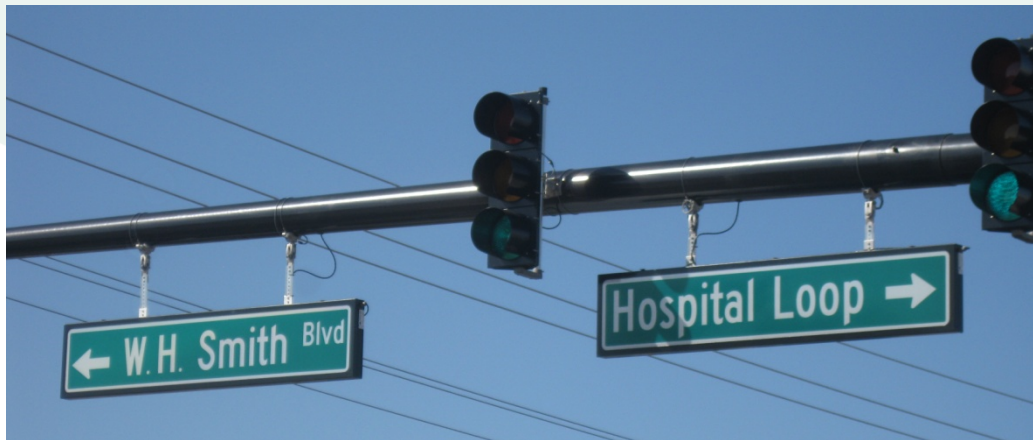

By combining advanced optics with our proven light engines that use Philips Rebel™ LEDs, we are proud to offer a truly innovative sign.

Thin Parallel Construction	Proven 60,000 hr. LEDs
Single & Double Faced	Easy to Maintain
Variable Viewable Heights	Quality Materials
Up to 10' Sign Faces	UL Listed
Rated at 150 MPH	FDOT Approved
Multiple Mounting Options	Relatively Light Weight

The LEDs are rated to maintain 70% of the initial brightness for 60,000 hours or 13.7 years at 12 hours per day and are extremely energy efficient. A double sided sign with a viewable area of 6' x 18" consumes only 28 watts of electricity or just over 122 kWh per year which translated to \$8.58 assuming 7 cents per kWh. Consequently, these signs may qualify for federal energy saving funding if used to replace older fluorescent signs.

These signs are housed in a traffic style continuously welded aluminum housing with strong polycarbonate signs faces. This construction is rated to withstand 150 MPH winds and meets all applicable state and local specifications. The housing is powder coated in black or any other FHWA approved colors including natural aluminum. Like Southern's illuminated street name signs, they are designed to be easy to install and maintain using only a screw driver or wrench. No tools are required to change lenses.

Dimensions

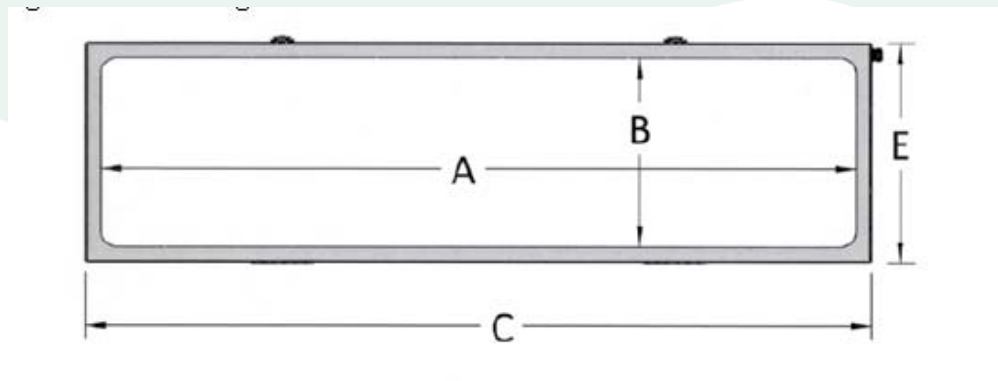

- A. Viewable length available in 1 foot increments from 4' to 10'
- B. Viewable height available in 1 inch increments from 12" to 27"
- C. Overall length is A + 3"
- D. Depth is 3.75" for a single sided sign and 5.15" for a double sided sign
- E. Overall height is B + 3", excluding brackets.

ENERGY CONSUMPTION IN WATTS						
	4' SS	6' SS	8' SS	4' DS	6' DS	8' DS
CLEAN PROFILE ≥ 18" TALL	21	28	36	21	28	36
CLEAN PROFILE ≥ 19" TALL	36	51	66	36	51	66

WEIGHT EXCLUDING BRACKETS - DOUBLE SIDED SIGNS						
	Weight in Ponds					
	4' X 19"	6' X 19"	8' X 19"	4' X 24"	6' X 24"	8' X 24"
CLEAN PROFILE	39	54	69	44	61	78

Customization Options:

- Logos, single or multi-color
- Retroreflective background
- Frame colors, black is standard
- Photocells
- Frame styles

Features:

- No tools required to open sign or replace lens.
- Energy Efficient Low Wattage 60,000 hour Rebel™ LEDs
- Radiant high temperature fail-safe circuit for LEDs to prevent premature burn out in extreme temperatures.
- Robust .125" 5052 aluminum housing
- Viewable area can be customized in heights ranging from 12" to 27" and lengths of 4' to 10'.
- Mounting options – tri-stud is standard, rigid mounting, and other mounting methods are available.
- Internal class 2 IP66 24v DC power supply with separate fuse.
- External junction box with power terminal strip and cord grip for easy installation.
- 7 year limited warranty.

For more information visit our website at www.southernmfg.com or send us an email to contactus@southernmfg.com. You can also contact us by phone at 407-894-8851. We have a nationwide network of distributors who can meet with you and show a sample of the clean profile sign.