

ITEM NO.	PART NUMBER	DESCRIPTION	Material	StockSize	QTY.
1	TOPMOUNTUBRKT		AISI 304	0.174	1
2	Hanger Angle 02		AISI 304	0.174	1
3	HBOLT 0.3750-16x1.5x1.5-N	HEX BOLT, 1/2-13 X 1.5, DRILL AS SHOWN			3
4	Preferred Narrow FW 0.5	FLAT WASHER, 1/2" BOLT			3
5	HHSBOLT 0.5000-13x2.25x2.25-N				1
6	91853A033	1/2-13 Slotted Hex Nut, 18-8 SS			1
7	Upper Swing Bracket Brkt 02		SEE SPEC	---	1
8	Lower Swing Bracket Brkt 02		SEE SPEC	---	1

REVISION HISTORY			
REV.	DESCRIPTION	DATE	APPROVED
D120612	INITIAL DESIGN	7/11/2012	JKH
D121012	CHANGED BOLT TO 3" LONG	10/12/2012	MNG

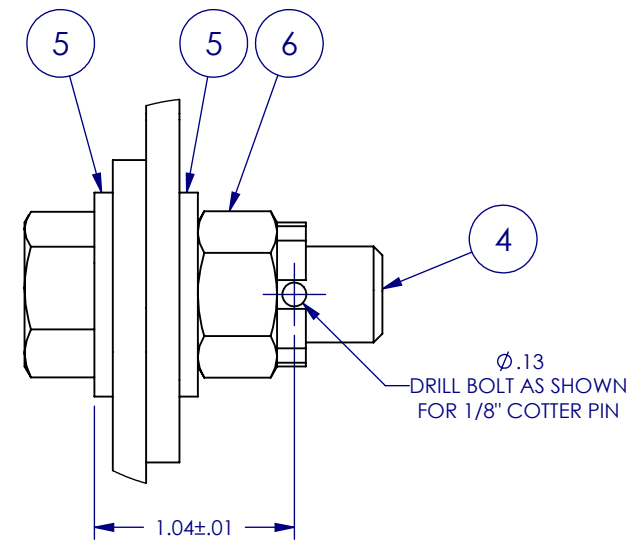

DETAIL A
SCALE 1 : 1

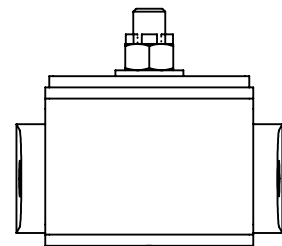
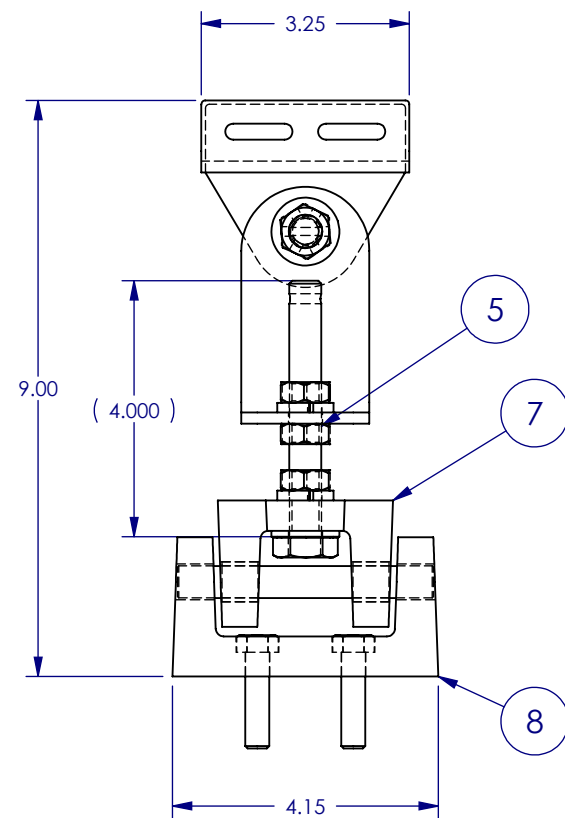
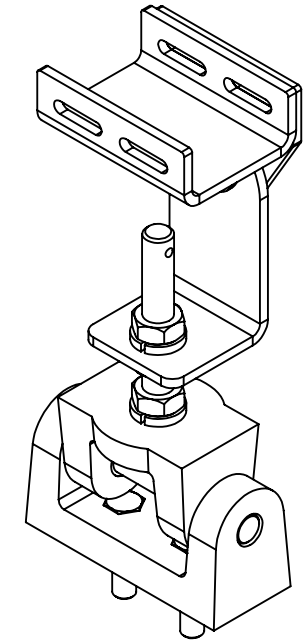

VENDOR WILL DRILL
PRIOR TO DELIVERY



DETAIL B
SCALE 1 : 2

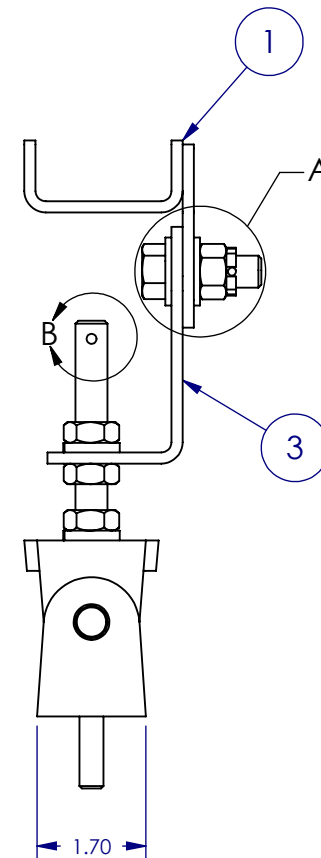

UNLESS OTHERWISE SPECIFIED ALL DIMENSIONS ARE IN INCHES TOLERANCES .X = ± .05 .XX = ± .03 .XXX = ± .01 ANGLES = ± 1.0	APPROVALS DRWN MNG 05/15/12 APRV BRE 05/15/12	CONFIDENTIAL PROPRIETARY INFORMATION OF: Earnest Products Inc. LONGWOOD, FLORIDA, USA 32750	
	FINISH NONE	TITLE T:\Southern Mfg - SOUH\Parts\LV Sign Hanger 01\ LV Brkt 02	
THIRD ANGLE PROJECTION	MATERIAL ""	WEIGHT 2.8262 LBS	DENSITY 0.1457
	SCALE 1:3	DWG NO. LV Brkt 02	SURF. AREA 175.2749
		REV D120612	SHEET 1 OF 2

ITEM NO.	PART NUMBER	DESCRIPTION	SW-Configuration Name(Configuration Name)	QTY.
1	TOPMOUNTBRKT		D120612	1
2	Hanger Angle 02		L1 6"	1
3	HBOLT 0.5000-13x1.5x1.25-N	HEX BOLT, 1/2-13 X 1.5, DRILL AS SHOWN	HBOLT 0.5000-13x1.5x1.25-N	1
4	Preferred Narrow FW 0.5	FLAT WASHER, 1/2 BOLT	Preferred Narrow FW 0.5	3
5	91853A033	1/2-13 Slotted Hex Nut, 18-8 SS	91853A033	1
6	Upper Swing Bracket Brkt 02		D120612	1
7	Lower Swing Bracket Brkt 02		D120612	1

REVISION HISTORY			
REV.	DESCRIPTION	DATE	APPROVED
D120612	INITIAL DESIGN	07/11/12	JKH

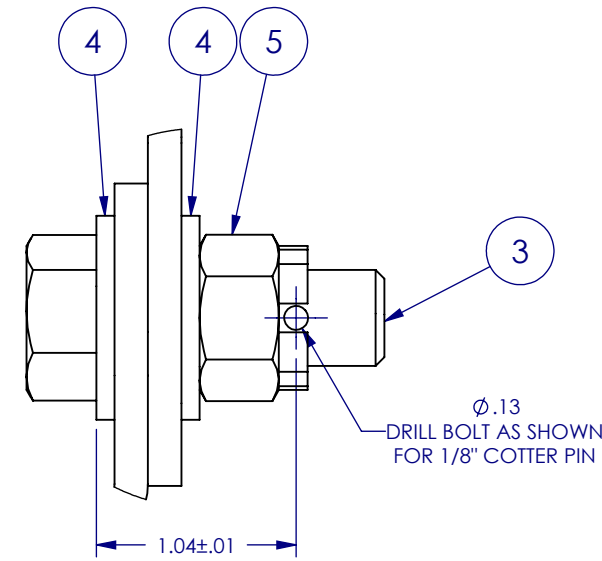
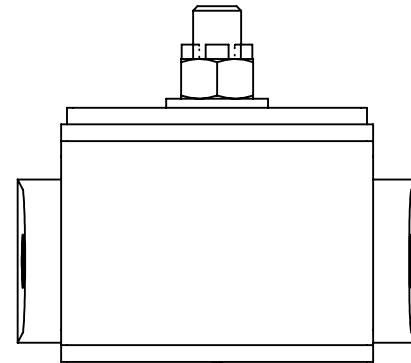

DETAIL C
SCALE 1 : 1

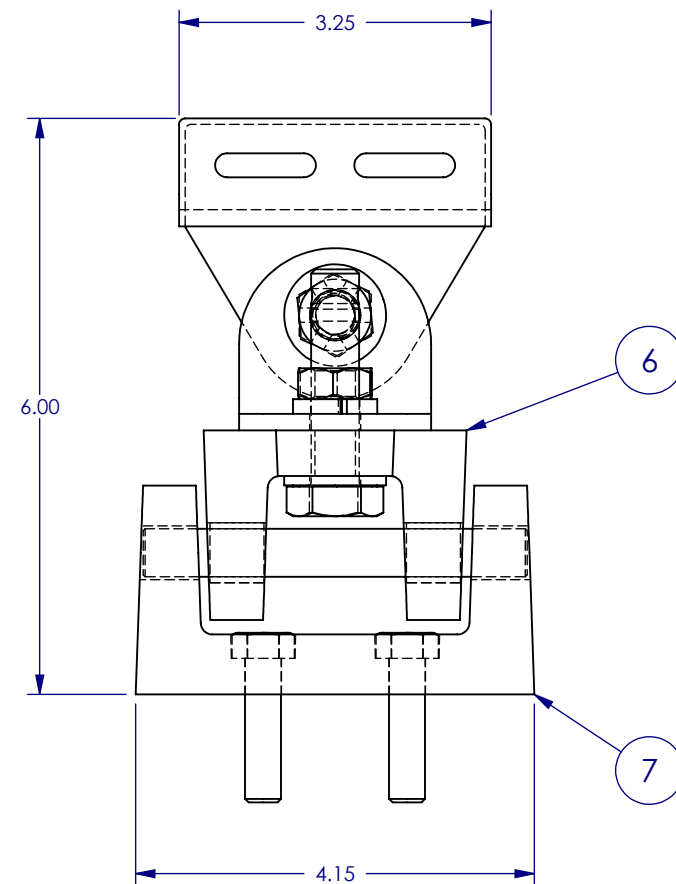
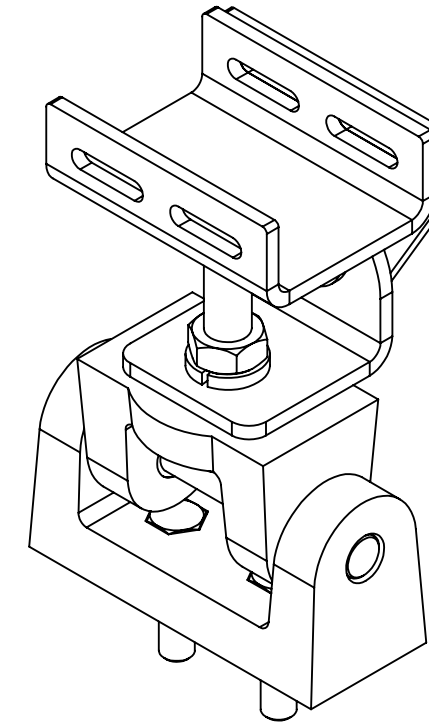

VENDOR WILL DRILL
PRIOR TO DELIVERY

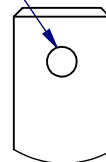

DETAIL D
SCALE 1 : 1

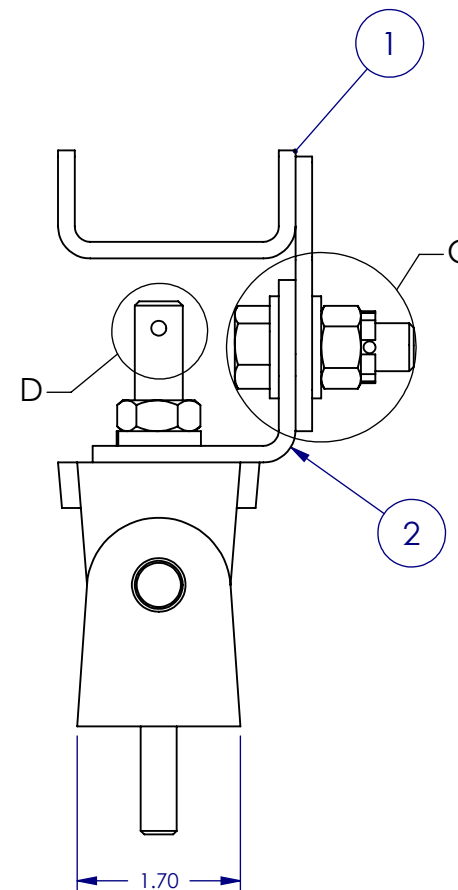

UNLESS OTHERWISE SPECIFIED ALL DIMENSIONS ARE IN INCHES TOLERANCES .X = ± .05 .XX = ± .03 .XXX = ± .01 ANGLES = ± 1.0	APPROVALS DRWN MNG 05/15/12 APRV BRE 05/15/12	CONFIDENTIAL PROPRIETARY INFORMATION OF: Earnest Products Inc. LONGWOOD, FLORIDA, USA 32750	
	FINISH NONE	TITLE T:\Southern Mfg - SOUH\Parts\LV Sign Hanger 01\ LV Brkt 02	
THIRD ANGLE PROJECTION	MATERIAL "	WEIGHT 2.8262 LBS	DENSITY 0.1457
	SCALE 1:2	SURF. AREA 175.2749	SHEET 2 OF 2
		DWG NO LV Brkt 02	REV D120612